

Liquid End Sheet

LE-81FS

When pumping solutions, make certain that all tubing is securely attached to the fittings. It is recommended that tubing or pipe lines be shielded to prevent possible injury in case of rupture or accidental damage. Always wear protective clothing and face shield when working on or near your metering pump.

Note: See parts list for materials of construction

A. INSTALLING INJECTION CHECK VALVE

1. The injection check valve should always be installed as close as possible to the point of solution injection.
2. Purpose of injection check valve is to prevent backflow from treated line.
3. A ½" NPT female fitting with sufficient depth will accept the injection check valve.
4. To insure correct seating of the ball inside the check valve, the injection check valve must be installed (vertically) upwards.

B. CONNECTING DISCHARGE TUBING

1. Discharge tubing is relatively stiff translucent tubing.
2. Route tubing from injection check valve to solution metering pump making sure it does not touch hot surfaces, sharp surfaces, or is bent so sharply that it kinks.
3. Slide small end of coupling nut onto tubing, then slide on the clamp ring.
4. Push tubing over tapered nozzle of discharge valve housing so that tubing flares out and reaches the shoulder (if tubing is stiff from cold, dip end in hot water).
5. Slide down the clamp ring and coupling nut until threads are engaged. Tighten by hand until tubing is held securely in place.

*Excessive force will crack or distort fittings.
DO NOT USE PIPE WRENCH.*

6. Follow the same procedure for connecting tubing to injection valve.

C. CONNECTING SUCTION TUBING

NOTE: Suction tubing is soft transparent tubing.

1. Cut suction tubing to a length such that foot valve hangs just above the bottom of the solution container. Maximum recommended vertical suction lift is 5 ft (1.5 m).
2. Follow same procedure (see **B. Connecting Discharge Tubing**) in connecting suction tubing to suction valve and foot valve.
3. If a suction tube straightener is desired, one may be fabricated from a 3 ft (1 m) piece of ¾" Schedule 80 PVC pipe.

4. Dip end of PVC pipe in hot water for at least one (1) minute to fit easily over end of coupling nut.
5. Push pipe over small end of coupling nut on top of foot valve.

D. PRIMING

1. Connect pressure release tubing to pressure release port.
2. Route tubing to solution reservoir and anchor with plastic tie provided.
3. Set pump at 80% speed and 100% stroke. Start pump.
4. Pull on Pressure Release knob (red or black knob), holding knob out until solution is visible through translucent return tubing.
5. Pump is now primed.

NOTE:

- (a) Pump is normally self-priming if suction lift is no more than 5 ft (1.5 m), valves in the pump are wet with water (pump is shipped from factory with water in pump head), and the above steps (**D. Priming**) are followed.
- (b) If the pump does not self-prime, remove Anti-Syphon/Pressure Release Valve Assembly and discharge valve ball, and pour water or solution slowly into discharge port until head is filled. Replace valve ball and follow steps **D. Priming** thereafter.

E. DEPRESSURIZING DISCHARGE LINE

1. It is possible to depressurize discharge line and pump head without removal of tubing or loosening of fittings.

Be sure injection check valve is properly installed and is operating. If a gate valve or globe has been installed downstream of injection check valve, it should be closed. Be certain relief tubing is connected and run to solution reservoir.

2. Pull on both anti-syphon and relief knobs.
3. The discharge line is now depressurized.
4. If injection check valve is of higher elevation than pump head, disconnecting tubing at injection check valve end will allow air to enter and cause solution to drain back to tank.



8 Post Office Square
Acton, MA 01720 USA
TEL: (978) 263-9800
FAX: (978) 264-9172
<http://www.lmipumps.com>



Replaces same of D 2/97
1536 E. 3/98

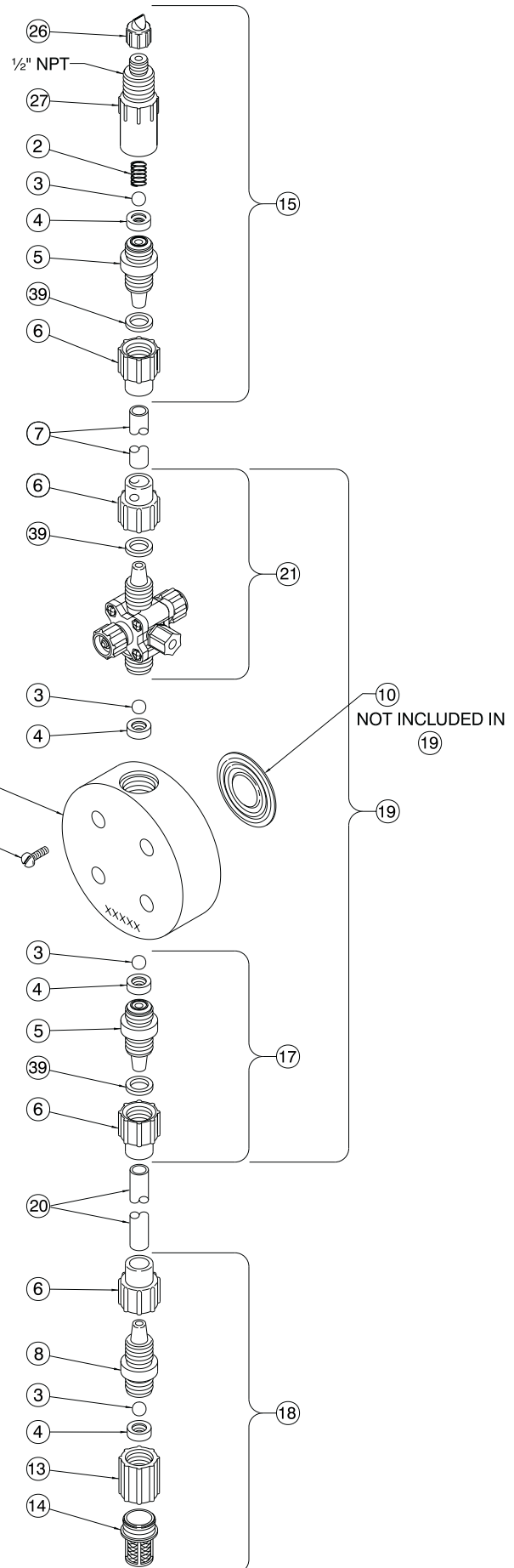
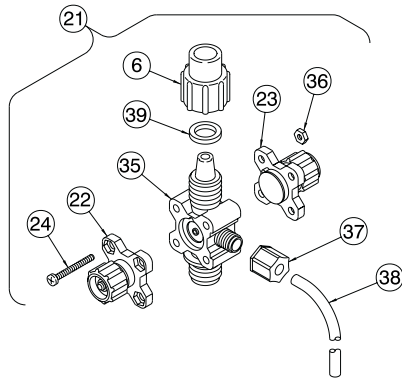

NOTE:
Threaded connections into pump head are 3/4"-16 straight threads. **DO NOT USE TEFLON® TAPE.** These joints are sealed by seal ring valve seats (item 5 on exploded view).

| KEY NO. | PART NO. | DESCRIPTION | QTY |
|---------|----------|---|-----|
| 2 | 29339* | Spring, PE | 1 |
| 3 | 10444* | Ball, PTFE .375 | 4 |
| 4 | 10107* | Seal Ring, Hypalon® | 4 |
| 5 | 10492 | Valve Seat, .500" PVC | 2 |
| 6 | 10411 | Coupling Nut | 4 |
| 7 | 10142-10 | Tubing, Polyethylene, .5" O.D. | 1 |
| 8 | 10493 | Valve Housing .500" PVC | 1 |
| 9 | 10340 | Screw, 10-24 x 3/4" S.S. | 4 |
| 10 | 10102* | Liquifram™, 0.9 SI, Hypalon® | 1 |
| 11 | 10113 | Head, Acrylic, 0.9 S.I. | 1 |
| 13 | 10978 | Foot Valve Seat | 1 |
| 14 | 10123 | Strainer, Polypropylene | 1 |
| 15 | 25273 | Inj. Check/Back Pressure Valve Asm | 1 |
| 17 | 25272 | Suction Valve Assembly | 1 |
| 18 | 25274 | Foot Valve Assembly | 1 |
| 19 | 25842 | Head Assembly, LE-81FS 0.9 | 1 |
| 20 | 10141-06 | Tubing, Vinyl, .5" O.D. | 1 |
| 21 | 30419 | Anti-Syphon/Press.Release Valve Asm | 1 |
| 22 | 30453 | Pressure Release Cap Assembly | 1 |
| 23 | 30452 | Anti-Syphon Cap Assembly | 1 |
| 24 | 25627 | Screw, 6-32 x 1 1/4" S.S. | 4 |
| 26 | 27352 | Flapper Valve | 1 |
| 27 | 10294 | Injector Fitting | 1 |
| 35 | 26856 | Valve Body, PVDF .500" | 1 |
| 36 | 25628 | Nut, 6-32 Hex S.S. | 4 |
| 37 | 25631 | Nut, Ferrule | 1 |
| 38 | 25636-10 | Tubing, Polyethylene, .250" O.D. | 1 |
| 39 | 37203 | Clamp Ring | 3 |
| --- | 32293 | Suction Tubing Straightener (not shown) | 1 |

*Parts included in Spare Parts Kit No. SP-U3.