

# LE-155LS

## LIQUID HANDLING ASSEMBLY

### CAUTION

When pumping solutions, make certain that all tubing is securely attached to the fittings. It is recommended that tubing or pipe lines be shielded to prevent possible injury in case of rupture or accidental damage. Always wear protective clothing when working on or near solution metering pump.

**NOTE: See parts list for materials of construction**

#### A. INSTALLING INJECTION CHECK VALVE

1. The injection check valve should always be installed as close as possible to the point of solution injection, at the very end of the tubing run.
2. Purpose of injection check valve is to prevent backflow from treated line.
3. A 1/2" NPT female fitting with sufficient depth will accept the injection check valve.
4. To insure correct seating of the ball inside the check valve, the injection check valve must be installed vertically upwards.

#### B. CONNECTING DISCHARGE TUBING

*NOTE: Cut tubing to length needed for discharge line.*

1. Route tubing from injection check valve to solution metering pump making sure it does not touch hot surfaces, sharp surfaces, or is bent so sharply that it kinks.
2. Slide small end of coupling nut onto tubing.
3. Slide the long, straight end of the ferrule onto tubing such that tubing exits at the cone shaped end of the ferrule.
4. Insert tubing into discharge valve housing so that tubing butts up against valve housing and will not go any further.
5. Slide ferrule down so that cone shaped end fits snugly into discharge valve housing.
6. Slide down the coupling nut until threads are engaged. Tighten coupling nut by hand, maintaining pressure on tubing towards valve housing until tubing is held securely in place.

*Excessive force will crack or distort fittings.  
DO NOT USE PIPE WRENCH.*

7. Follow the same procedure for connecting tubing to injection valve.

#### C. CONNECTING SUCTION TUBING

1. Cut suction tubing to a length that the foot valve hangs just above the bottom of the solution container. Maximum recommended vertical suction lift is 5 ft. (1.5m).

2. Follow same procedure (see B) in connecting suction tubing to suction valve and foot valve.

#### D. PRIMING

1. Connect pressure release tubing to pressure release port.
2. Route tubing to solution reservoir and anchor with plastic tie provided.
3. Set pump at 80% speed and 100% stroke. Start pump.
4. Pull on pressure release knob (red or black knob), holding knob out until solution is visible through translucent return tubing.
5. Pump is now primed.

*NOTE:*

*(a) Pump is normally self-priming if suction lift is no more than 5 ft. (1.5m), valves in the pump are wet with water (pump is shipped from factory with water in pump head) and the above steps (D1 thru D5) are followed.*

*(b) If the pump does not self-prime, remove discharge valve housing and ball and pour water or solution slowly into discharge port until head is filled. Follow steps D1 thru D5 thereafter.*

#### E. DEPRESSURIZING DISCHARGE LINE

1. It is possible to depressurize discharge line and pump head without removal of tubing or loosening of fittings.

Be sure injection check valve is properly installed and is operating. If a gate valve or globe has been installed, downstream of injection check valve, it should be closed. Be certain relief tubing is connected and run to solution reservoir.

2. Pull on both anti-syphon and relief knobs.
3. The discharge line is now depressurized.
4. If injection check valve is of higher elevation than pump head, disconnecting tubing at injection check valve end will allow air to enter and cause solution to drain back to tank.



**LMI**  
LIQUID METRONICS DIVISION  
**MILTON ROY**

8 Post Office Square  
Acton, MA 01720 U.S.A.  
TEL (508) 263-9800  
FAX (508) 264-9172

**NOTE:**

Threaded connections into pump head are 3/4"-16 straight threads. **Do not use Teflon tape.** These joints are sealed by seal ring valve seats (item 5 on exploded view).

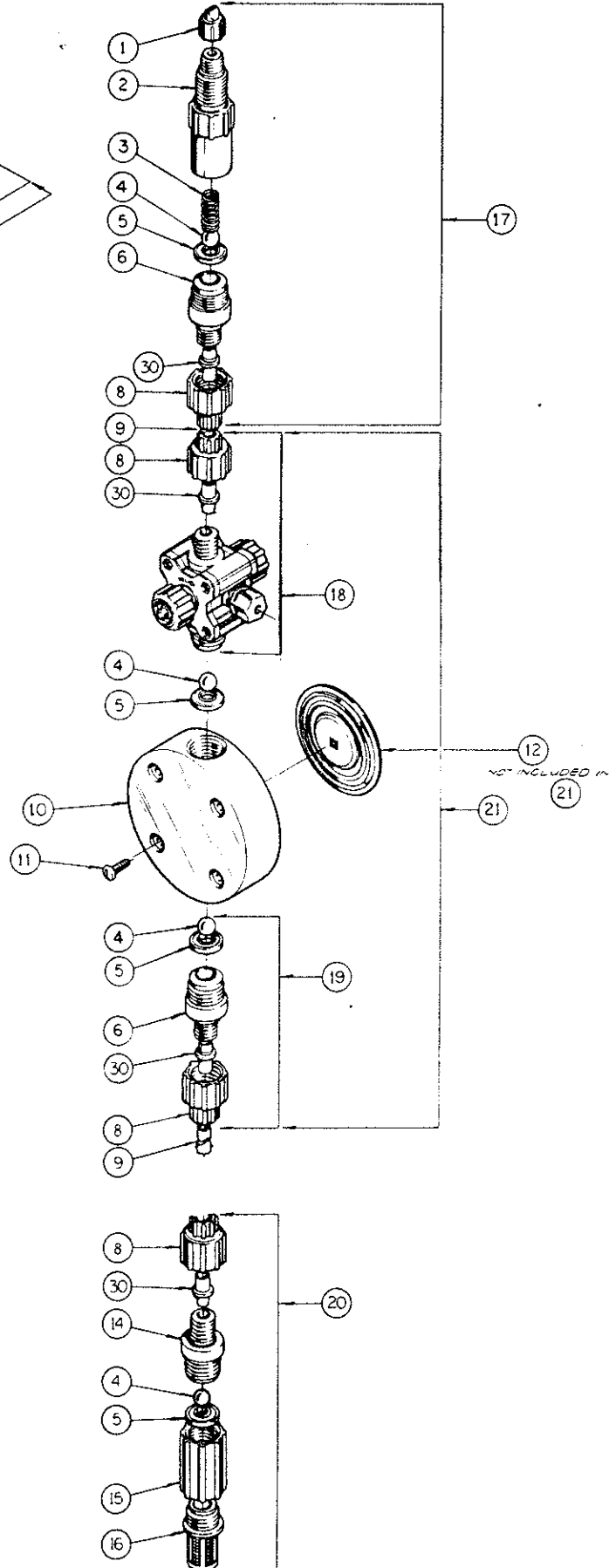
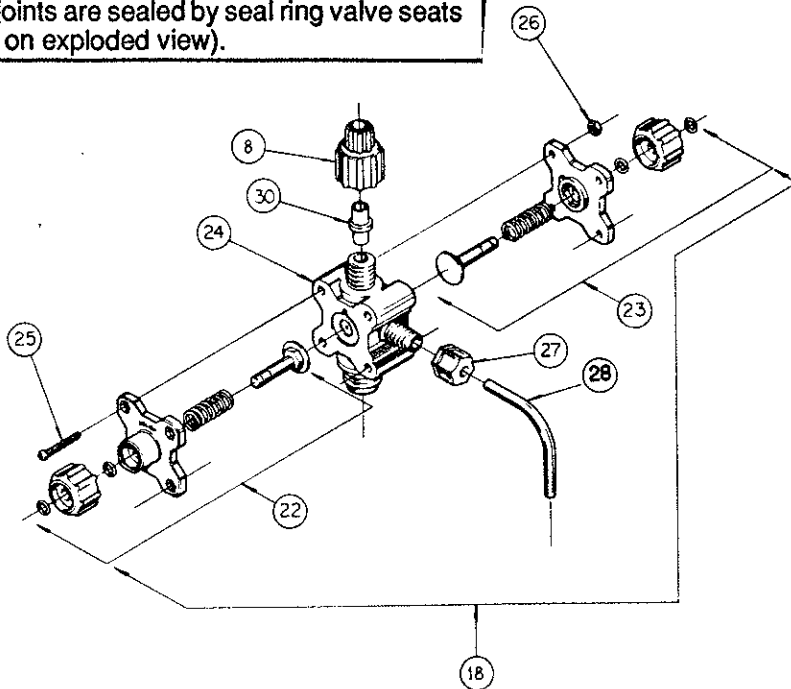

**LE-155LS**

KEY NO.	PART NO.	DESCRIPTION	QTY.
1	27352	Flapper Valve	1
2	10394	Injector Fitting, Polypropylene	1
3	10339*	Spring, PVDF	1
4	10338*	Ball, Ceramic, .375	4
5	29443*	Seal Ring, Polyprel	4
6	28664	Valve Seat, GFR Polypropylene	2
8	10299	Coupling Nut	4
9	25636-16	Tubing, .250" O.D. Polyethylene	1
10	27877	Head, 0.5 SI GRF Polypropylene	1
11	10340	Screw, 10-24 x 3/4" S.S.	4
12	26042*	Liquifram™, 0.5 SI Teflon	1
14	28665	Valve Housing, GFR Polypropylene	1
15	10978	Foot Valve Seat	1
16	10123	Strainer, Polypropylene	1
17	28001	Inj. Check/Back Pressure Valve Asm	1
18	28010	Anti-Syphon/Pressure Relief Valve Asm	1
19	28004	Suction Valve Assembly	1
20	28002	Foot Valve Assembly	1
21	32269	Head Assembly, LE-155LS	1
22	25837	Relief Cap Assembly	1
23	25838	Anti-Syphon Cap Assembly	1
24	28703	Valve Body, GFR Polypropylene	1
25	25627	Screw, 6-32 S.S.	4
26	25628	Nut, Hex 6-32 x 1 1/4" S.S.	4
27	25631	Coupling Nut	1
28	25636-10	Tubing, .250" O.D. Polyethylene	1
30	28663	Ferrule, PP	4
	32293	Suction Tubing Straightener (not shown)	1

\*Parts included in Spare Parts Kit SP-U8