



Pulsation Dampener Instruction Manual

INSPD-9003-R00

Made in the USA

Call: 1 - 800 - GRIFFCO

Website: www.griffcovalve.com

TABLE OF CONTENTS

Safety Precautions:

Limited Warranty:

Introduction:

Description

Product Coding

Installation and Operation:

Unpacking:

Installation:

Start-up

Pressure Adjustment

Typical Installation Drawing

Maintenance:

Maintenance

- Disassembly

- Reassembly

Parts List

Specifications:

Technical Data

Dimensions

Notes:

PLEASE READ THE FOLLOWING INFORMATION PRIOR TO INSTALLING GRIFFCO VALVE PRODUCTS. FAILURE TO FOLLOW THESE INSTRUCTIONS MAY RESULT IN INJURY

Safety Symbols:

 **WARNING:** Hazardous or unsafe practices could cause serious injury, death or severe property damage.

 **CAUTION:** Hazardous or unsafe practices could cause injury, death or equipment damage.

Dampeners should only be installed and maintained by trained personnel.

- 1. Griffco Valve guarantees its products against defective material and workmanship only. Griffco Valve assumes no responsibility for damage or injuries resulting from improper installation, misapplication, or abuse of any product.*
- 2. Griffco Valve assumes no responsibility for damage or injury resulting from chemical incompatibility between its products and the process fluids to which they are subjected. Compatibility charts provided in Griffco Valve literature are based on ambient temperatures of 70°F and are for reference only. Customers should always test to determine application suitability.*
- 3. Consult Griffco Valve literature to determine operating pressure, temperature, and flow rate limitations before installing any Griffco Valve product. Also note that maximum operating pressure is dependent upon material selection as well as operating temperature. Do not exceed maximum pressure rating.*
- 4. This product is designed primarily for use with non-compressible liquids.*
- 5. Systems should always be depressurized, flushed and drained prior to installing or maintaining Griffco Valve products.*
- 6. Before starting a chemical feed system ensure all downstream valves are open and that the Griffco Valve relief valve is in working order.*
- 7. Do not operate a chemical feed system that has damaged or leaking equipment.*
- 8. Temperature effect on piping systems should always be considered when the systems are initially designed. Piping systems must be designed and supported to prevent excess mechanical loading on Griffco Valve equipment due to system misalignment, weight, shock, vibration, and the effects of thermal expansion and contraction.*
- 9. Due to differential thermal expansion rates between metal and plastic, transmittal of pipe vibration, and pipe loading forces **DIRECT INSTALLATION OF METAL PIPE INTO PLASTIC CONNECTIONS IS NOT RECOMMENDED.** Wherever installation of plastic pulsation dampeners into metal piping systems*

is necessary, it is recommended that at least 10 pipe diameter in length of plastic pipe be installed upstream and downstream of the plastic dampener to compensate for the factors mentioned above.

10. *Griffco pulsation dampeners are designed to operate with compressed air (up to 150 psi), and dry nitrogen only. DO NOT USE OXYGEN.*
11. *Ensure internal dampener pressure is released, isolation valves are closed, the chemical feed system is shut down and system pressure released before performing any maintenance or dampener removal.*
12. *When pumping flammable liquids or in a flammable environment, ensure the pulsation dampener and chemical feed system are grounded to avoid possible explosion due to static spark.*



CAUTION

Hazardous Misuse of Equipment:

1. **DO NOT USE OXYGEN TO CHARGE PULSATION DAMPENER.** *Misuse could result in injury, death, explosion or property and equipment damage.*
2. *Temperature and pressure limits as outlined in the Griffco technical literature and on the equipment label must be adhered to.*
3. *Install the pulsation dampener before charging or pressurizing. Charge the dampener before pressurizing the chemical feed system. Do not over pressurize the dampener.*
4. *Dampener bladders break down over time. Failures allow the system fluid into the air chamber and will cause damage to the charging assembly. Routine maintenance should be performed.*
5. *Do not overtighten dampener at the connection to the chemical feed system. Overtightening can weaken the dampener housing at that point.*



WARNING

Important Information:

1. **Do not use oxygen to charge pulsation dampener due to risk of explosion.** *Use only compressed air (up to 150 psi), or dry nitrogen.*
2. *Never exceed maximum pressure as indicated on the dampener label.*
3. *Never exceed the maximum temperature as indicated on the dampener label.*
4. *Ensure chemical compatibility before installing and pressurizing dampener.*
5. *Always follow OSHA safety requirements. Wear protective clothing and eyewear when working on any equipment in the chemical feed system.*
6. *Never operate a chemical feed system that has components that are leaking, corroded, damaged or in need of service.*
7. *Refer to the MSDS for all chemicals used*
8. *Use only Genuine Griffco parts for service. Use of other parts may result in damage to equipment or injury and invalidate the warranty.*
9. *Flush all components that are in contact with chemicals prior to servicing.*
10. *Dispose all chemicals and waste according to all local, state and federal regulations.*
11. *Always install a pressure relief valve in the system.*

LIMITED WARRANTY

Griffco Valve Inc. (“GVI”) warrants that its products shall be free from defects in material and workmanship for a period of one year under normal use or eighteen (18) months from date of shipment, whichever first occurs. Defects caused by shipment, improper installation, negligence or misuse by parties other than GVI are not covered by this limited warranty. This limited warranty is extended only to the original purchaser from GVI.

The purchaser must promptly notify GVI of any claimed defect. Products may only be returned to GVI upon purchaser’s receipt of written consent from GVI. Products are to be returned to GVI with freight prepaid. If GVI’s inspection shows the products to be defective, GVI’s liability in respect of defective products shall be to repair or replace such item(s) at its discretion.

EXCEPT FOR THE EXPRESS LIMITED WARRANTY SET FORTH HERE, NO OTHER IMPLIED WARRANTIES OF ANY KIND, INCLUDING BUT NOT LIMITED TO IMPLIED WARRANTIES OF MERCHANTABILITY OR FITNESS FOR A PARTICULAR PURPOSE OR USE, ARE HEREBY DISCLAIMED. GVI SHALL NOT BE LIABLE FOR ANY DIRECT, INDIRECT, SPECIAL, INCIDENTAL OR CONSEQUENTIAL DAMAGES OR LOSSES.

GVI’S MAXIMUM LIABILITY SHALL NOT IN ANY EVENT EXCEED THE CONTRACT PRICE FOR THE PRODUCT.

INSTALLATION

Unpacking:

Units are shipped FOB factory and the title passes to the customer when the carrier signs for the receipt of the unit. In the event damages occur during shipment, it is the responsibility of the customer to notify the carrier immediately and to file a damage claim.

Check all orders for completeness against the packing list. Notify Griffco Valve Inc. immediately if any deficiencies are found.

Each carton should contain:

- 1 Pulsation Dampener
- 1 Instruction Manual
- Accessories as ordered

Installation:

WARNING

1. Turn off and lock out the chemical feed pump. Bleed off all pressure from the system before starting to install the dampener.
2. Remove any pressure from the dampener.
3. Use compressed air (up to 150 psi) or dry nitrogen to charge the dampener. **DO NOT USE OXYGEN.**
4. Do not exceed the maximum allowable pressure for the dampener as stated on the dampener label.
5. Always follow OSHA procedures and wear protective eyewear and clothing.
6. Charge dampener to 80% of system pressure before testing.
7. It is not recommended threading metal pipe or pipe fittings into plastic components.



CAUTION -

Temperature Limits

Thermoplastics & Elastomers:

Material	General Chemical Resistance	Limits
PVC	Resistant to most Solutions of acids, alkalis, salts and organic compounds miscible with water.	+32°F - +140°F
CPVC	Similar properties to PVC, but with increased temperatures	+32°F - +180°F
PP	Resistant to water solutions of acids, alkalis and salts, as well as to many organic solvents. Unsuitable for concentrated oxidizing acids	+32°F - +175°F
PVDF	Resistant to acids, aliphatic, aromatic & chlorinated hydrocarbons, alcohols & halogens. Conditionally for ketones, esters, ethers, alkaline soln. & bases	+10°F - +225°F
Noryl®	Excellent resistance to Sodium Hypochlorite, Sulphuric Acid and Sodium Hydroxide	+32°F - +225°F
EPDM	Good resistance to aggressive chemicals. Unsuitable for oils & fats	-60°F - +280°F
Hypalon®	Good in most acid applications	-20°F - +275°F
Viton®	Has best chemical resistance to solvents of all elastomers	-10°F - +300°F



CAUTION -

Plastic materials lose tensile strength as temperatures rise. This reduces the maximum working pressure of the dampener. Appropriate derating factors must be applied to the maximum working pressure when operating above 75° F. Where the risk of fire exists that could potentially cause the pre-charge gas to rise above the maximum working pressure rating a relief device must be installed on the gas side of the dampener.

Prior to installation: check that the connection is the right size. Review the specification on the dampener tag to validate the correctness of the model size, material and pressure.

INSTALLATION

As a general rule, installation should follow the layout as outlined in the TYPICAL INSTALLATION drawing.

The dampener should be installed as close to the pump discharge as possible, but downstream of the pressure relief valve. Generally, the dampener should be mounted in the vertical position, either way up, however it will work in a horizontal position. Keep the piping as short as possible as longer pipe lines will reduce dampening effectiveness.

Dampeners should be mounted with a support bracket whenever possible and always when using flexible tubing.

Mount a pressure gauge downstream of the dampener and before the installation of a Griffco back pressure valve. The adjustable back pressure valve will ensure a constant upstream pressure and will facilitate the fine adjustment of the pressure to minimize the pulsations from the pump.

Pre-charge the dampener to 80% of the anticipated injection pressure (Compressed air to 150 psi, nitrogen above 150 psi), and replace the air valve cap, hand tighten. Using a soapy solution check the charging assembly and connection to the dampener for any air leaks. If no leaks are present, check that all downstream valves are open; then turn on chemical feed pump.

Check the gauge installed between the dampener and the back pressure valve. It should initially bounce as pressure is built up and stabilize once the charge pressure is equalized. **Use the back pressure valve adjustment screw to fine tune the dampening effect. If a back pressure valve is not installed adjust the air pressure to minimize the needle movement.**

TYPICAL INSTALLATION

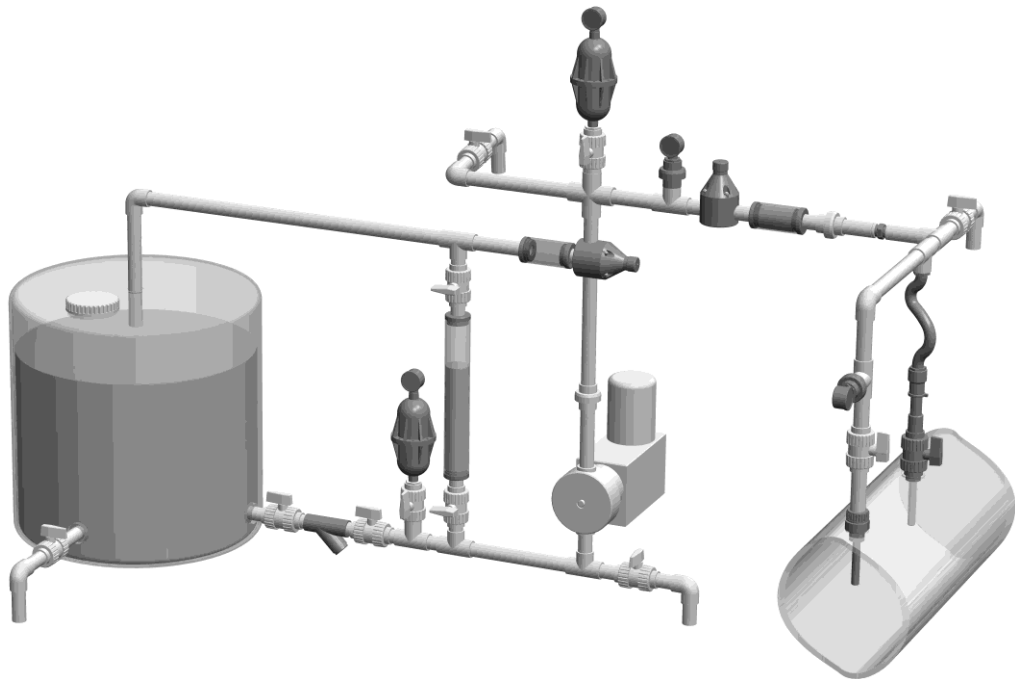

MAINTENANCE

General:

Griffco pulsation dampeners were designed with a minimum amount of maintenance required to keep the equipment in operation. However, periodic replacement of the bladder is required.

The Griffco design permits routine inspection and repair without removing the dampener from the pump line, provided an isolation valve is installed.



CAUTION -

Ensure that the chemical feed system is not under pressure and in the absence of an isolation valve, that the chemical lines have been flushed with water before starting disassembly. Always wear protective clothing and eyewear when working on the chemical feed system. Use only genuine Griffco parts in your Griffco Dampener.

Disassembly:

If an isolation valve is installed ensure it is open; then increase the pressure in the dampener to 5 psi higher than the system pressure. This will force most of the chemicals out of the dampener. Close the isolation valve. Release the air from the dampener via the charging assembly.

If an isolation valve is not installed, depressurize the entire chemical feed system, drain the system and flush with water. Release the air from the dampener via the air charging system. Check the pressure gauge to ensure it is reading zero pressure.

Undo the 8 bolts holding the 2 halves of the dampener together. Lift the top half of the dampener off and remove the bladder.

Use only genuine Griffco parts in your Griffco Dampener.

Reassembly:

Place a small amount of grease (PTFE or silicone) on the bladder seat of both the top and bottom halves of the dampener.

Place the bladder into the bottom half of the dampener. (The side connected to the chemical feed system). Replace the top half of the dampener, ensuring the bladder o ring is correctly positioned. It is strongly recommended that nuts and bolts be replaced every time the dampener is disassembled for maintenance or inspection. Reinstall the bolts and nuts and torque to 1 ft./lb. for size 1 & 2 and _ ft./lb. for size 3.

With the isolation valve still closed pre-charge the dampener via the charging assembly to 80% of the anticipated system pressure. Used compressed air up to 150 psi, dry nitrogen for pressures above 150 psi. **DO NOT USE OXYGEN due to risk of explosion.**

Using a soapy solution check the charging assembly and connection to the dampener for any air leaks. If no leaks are present check that all downstream valves are open; then turn on chemical feed pump.

Once the chemical feed system is up to pressure open the isolating valve under the pulsation dampener. Using the back pressure valve, adjust the upstream pressure to maximize the dampening effect.

SPARE PARTS

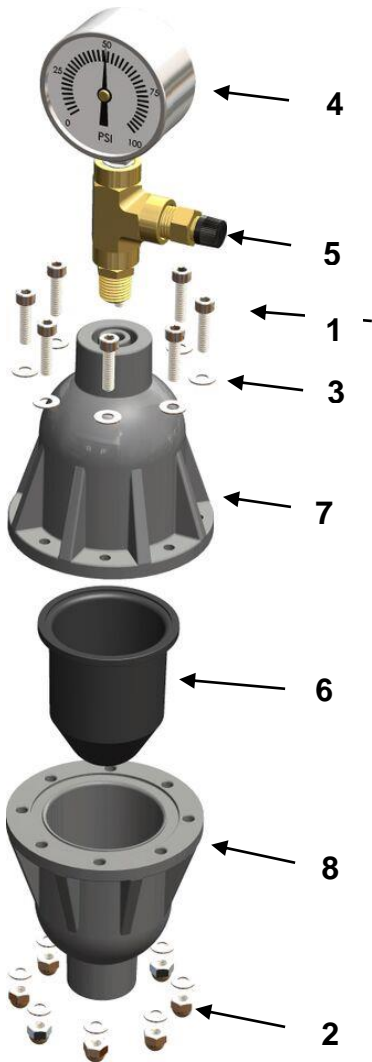

PARTS LIST

ITEM	DESCRIPTION	PART #
1	10/32 X 3/4 Stainless Steel Bolt 10/32 X 1 1/4 Stainless Steel Bolt 1/4 – 20 X 1 3/8” Stainless Steel Bolt	PV-00107 PV-00114 PV-00121
2	10/32 Cap hex nut 1/4-20 Cap hex nut	PV-00201 PV-00202
3	10/32 Flat washer 1/4 -20 Flat washer	PV-00301 PV-00302
4	0 – 60 psi Gauge, painted steel case, brass connection 0 – 100 psi Gauge, painted steel case, brass connection 0 – 160 psi Gauge, painted steel case, brass connection 0 – 200 psi Gauge, painted steel case, brass connection 0 – 60 psi Gauge, stainless steel case, brass connection 0 – 100 psi Gauge, stainless steel case, brass connection 0 – 160 psi Gauge, stainless steel case, brass connection 0 – 200 psi Gauge, stainless steel case, brass connection 0 – 60 psi Gauge, stainless steel case, stainless connection 0 – 100 psi Gauge, stainless steel case, stainless connection 0 – 160 psi Gauge, stainless steel case, stainless connection 0 – 200 psi Gauge, stainless steel case, stainless connection	GG3060 GG3100 GG3160 GG3200 GG3SB060 GG3SB100 GG3SB160 GG3SB200 GG3SS060 GG3SS100 GG3SS160 GG3SS200
5	Charging assembly without gauge – 1/8” connection Brass Charging assembly without gauge – 1/4” connection Brass Charging assembly without gauge – 1/8” connection Brass Charging assembly without gauge – 1/4” connection Brass	PDCA018B PDCA025B PDCA018SS PDCA025SS
6	PD001 small bladder – EPDM (for 6 cu in dampener) PD001 large bladder – EPDM (for 10 and 15 cu in dampener) PD001 small bladder – Viton® (for 6 cu in dampener) PD001 large bladder – Viton® (for 10 and 15 cu in dampener) PD001 small bladder – Hypalon® (for 6 cu in dampener) PD001 large bladder – Hypalon® (for 10 and 15 cu in dampener) PD002 small bladder – EPDM (for 16 cu in dampener) PD002 large bladder – EPDM (for 29 and 42 cu in dampener) PD002 small bladder – Viton® (for 16 cu in dampener) PD002 large bladder – Viton® (for 29 and 42 cu in dampener) PD002 small bladder – Hypalon® (for 16 cu in dampener) PD002 large bladder – Hypalon® (for 29 and 42 cu in dampener) PD003 small bladder – EPDM (for 36 cu in dampener) PD003 large bladder – EPDM (for 80 and 125 cu in dampener) PD003 small bladder – Viton® (for 36 cu in dampener) PD003 large bladder – Viton® (for 80 and 125 cu in dampener) PD003 small bladder – Hypalon® (for 36 cu in dampener) PD003 large bladder – Hypalon® (for 80 and 125 cu in dampener)	PDD0016 PDD0010 PDD0017 PDD0011 PDD0018 PDD0012 PDD0026 PDD0020 PDD0027 PDD0021 PDD0028 PDD0022 PDD0036 PDD0030 PDD0037 PDD0031 PDD0038 PDD0032

7	<p>PD001 dampener top – Noryl® PD002 dampener top – Noryl® PD003 dampener top – Noryl® PD001 dampener top – PP PD002 dampener top – PP PD003 dampener top – PP</p> <p>PD001 dampener top – PVDF PD002 dampener top – PVDF PD003 dampener top – PVDF</p>	<p>PDP00111N PDP00211N PDP00311N</p> <p>PDP00111PP PDP00211PP PDP00311PP</p> <p>PDP00111K PDP00211K PDP00311K</p>
8	<p>PD001 dampener base – Noryl® PD002 dampener base – Noryl® PD003 dampener base – Noryl®</p> <p>PD001 dampener base – PP PD002 dampener base – PP PD003 dampener base – PP</p> <p>PD001 dampener base – PVDF PD002 dampener base – PVDF PD003 dampener base – PVDF</p>	<p>PDP00112N PDP00212N PDP00312N</p> <p>PDP00112PP PDP00212PP PDP00312PP</p> <p>PDP00112K PDP00212K PDP00312K</p>

Technical Data:

Materials of Construction:	Body: Noryl® , PP, PVDF, 316 SS; Top: Noryl®, 316 SS
Connection Sizes:	1/2", 3/4" and 1"
Connections:	NPT, BSPT, Union, Flange
Gauge Port Sizes	1/8", 1/4" and 1/2"
Max Temperature: (°F)	PP: 175° ; PVDF: 225°; Noryl: 225°; 316SS: Bladder Dependant
Max Operating Pressure (psi) @ 70 Deg. F	Plastic: 150 psi (Peak: 250 psi) 316 SS: 250 psi (Peak: 350 psi)
Diaphragm Material	Std: EPDM, Optional: Viton®, Hypalon
Gauge and Charging Valve Materials	Std.: Brass, Optional: 316 SS
Dampening Effect	± 2.5%
Optional Gauges	Standard: 0 – 160 psi; Optional: 0 – 60 psi, 0 – 100 psi, 0 – 200 psi

Dimensions:

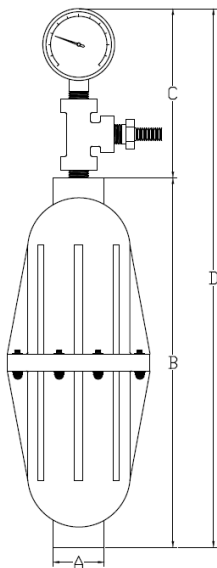

Model	Capacity (cu in)	A (in)	B (in)	C(in)	D (in)
PD0011	6.0	1/2	4.23	4.20	8.43
PD0012	10.0	1/2	5.70	4.20	9.90
PD0013	15.0	1/2	7.15	4.20	11.35
PD0021	16.0	3/4	5.26	4.40	9.66
PD0022	29.0	3/4	7.76	4.40	12.16
PD0023	42.0	3/4	10.26	4.40	14.66
PD0031	36.0	1	5.79	4.40	10.19
PD0032	80.0	1	9.90	4.40	14.30
PD0033	125.0	1	14.00	4.40	18.40

NOTES

Pulsation Dampener Information:

Product Code: _____

Serial Number: _____

Body Material: _____

Bladder Material: _____

Installation Date: _____

Vendor: _____

Contact: _____

Phone: _____

Email: _____



Manufactured By:
Griffco Valve Inc.
6010 N. Bailey Ave., Ste. 1B
Amherst, NY 14226

NOTES



**Griffco Valve Inc.
6010 N. Bailey Ave., Ste. 1B
Amherst, NY 14226
USA**

Phone: 1-800-GRIFFCO (800-474-3326)

+1-716-835-0891

Fax: +1 716-835-0893

E-Mail: sales@griffcovalve.com

Website: www.griffcovalve.com