

WINGERT *GLYCOL*

FEED SYSTEMS

Engineered for Performance

Glycol feed applications come in all shapes and sizes. Unfortunately, until now glycol feed systems did not.

With three standard models and a long list of custom options, Wingert heavy-duty, automated Glycol Feed Systems deliver a comprehensive package of operational features that meet the specific requirements of virtually any closed loop system.

Manufactured to exacting standards, Wingert Glycol Feed Systems offer the flexibility of various pressure ranges, motor sizes, instrumentation and much more. Regardless of the application, there is a Wingert Glycol Feed System to do the job.



J.L. WINGERT CO.

FEATURES

- Industrial grade 1/4" thick polyethylene tank
- Integral one piece carbon steel stand
- Pump capacity output 1.3 GPM at 100 psi (2.2 GPM at 0 psi)
- 1/3 hinged polyethylene cover
- 3-30 psi, 10-50 psi and 40-100 psi available pressure ranges
- NEMA 4X control panel
- 10 amp relay
- 8 ft. power cord
- 1/2 HP gear pump optional (3 GPM at 100 psi)
- Audible alarm and silence switch available
- Optional remote dry contact on low level for PLC interface or control room alarm

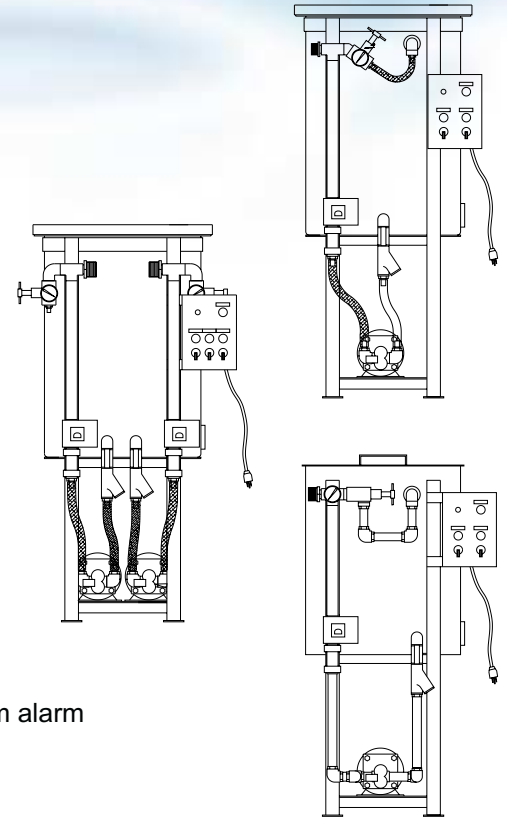

ECONOMY SYSTEM

Model GL50-E

- 1/3 HP gear pump
- NEMA 4X control panel
- 50 gallon polyethylene tank with carbon steel stand
- Low level float switch
- Pressure switch and gauge
- PVC pressure relief valve

DUAL ECONOMY SYSTEM

Model GL50-2E

- (2) 1/3 HP gear pumps
- NEMA 4X control panel
- 50 gallon polyethylene tank with carbon steel stand
- Low level float switch
- (2) Pressure switches and gauges
- (2) PVC pressure relief valves

HIGH TEMPERATURE SYSTEM

Model GL50-H

- 1/3 HP gear pump
- NEMA 4X control panel
- 50 gallon carbon steel tank and stand coated with corrosion resistant epoxy paint
- Low level float switch
- Pressure switch and gauge
- Brass pressure relief valve